

Dealer Signage Solutions

SERVICES

- Interior Signage
- Exterior Signage
- Electronic Message Centers
- Design & Layout
- Field Surveys
- Installations
- Inventory
- Permitting

CORE ELEMENTS

Pick and choose core components to create your own custom store layout.

Your store environment should provide a consistent, cohesive message about who you are. Signs and graphics play a lead role in communicating store identity and establishing a store image. Effective and exciting store graphics and signage, combined with appealing design and décor choices, actively contribute to an in-store experience that will mean return visits and loyal customers. Each of the elements listed below play a vital role in enhancing the in-store experience.



END CAP PRICE POINT SIGNAGE

Provides advertising and price display for items that are being featured on the fixed end cap. This sign includes spiral-bound pricing numbers and symbols along with 5 different readings. Point-of-Purchase items have become one of the most effective sales vehicles available to all retailers.



RECTANGULAR END CAP SIGNAGE

Rectangular End Cap Signs are all-encompassing, providing both aisle and end cap signage in one. This sign can include number panels and aisle name panels on both lateral ends with 6 customizable inserts. It also includes spiral-bound pricing numbers and a panel for your brand logo or a graphic.



AISLE DIRECTORY SIGNAGE

Triangle Aisle Directories are designed to provide maximum visibility from any viewing angle to direct customers to your products. Hanging Aisle Directories have versatility and can be placed in an aisle or over a fixture row. Change able inserts allow for flexibility in department layout.



HANGING DEPARTMENT SIGNAGE

Bold, double-sided overhead department signs inform the customer as to the overall layout of the store and guide them to core departments. Creative full-color design provides maximum impact and promotes the message that a wide selection of quality merchandise will be on hand.



HANGING CIRCULAR SIGNAGE

Hanging Circular Signs create visual impact through the use of shape, dimension, and color. Lightweight, durable PVC encased foam, striking dimensional or printed lettering, and eye-catching graphics provide dynamic area identification and architectural signage.



CATEGORY MANAGEMENT

Total Category Management (TCM) Signs and Aisle Violator Signs help to navigate aisle content. One-sided TCMs include mounting hardware to easily attach to fixture pegboard. Aisle Violators are double-sided, vertical signs that jut directly from fixtures to divide product into categories.

END CAP SIGNAGE

Provides advertising and price display for items that are being featured on the fixed end cap. This sign works well alongside endcap directory signage like the Triangle Aisle Directory and the Trapezoid Aisle Directory.

This sign includes 5 spiral bound pricing numbers and symbols along with insert channels and six interchangeable readings:

- NEW ITEM
- CLEARANCE
- SPECIAL BUY
- AS ADVERTISED
- SALE
- EVERYDAY VALUE



A	PANEL CAN BE A SOLID COLOR OR PRINTED GRAPHIC.
B	6 INTERCHANGEABLE, CUSTOMIZABLE READINGS SUPPLIED W/ SIGN.

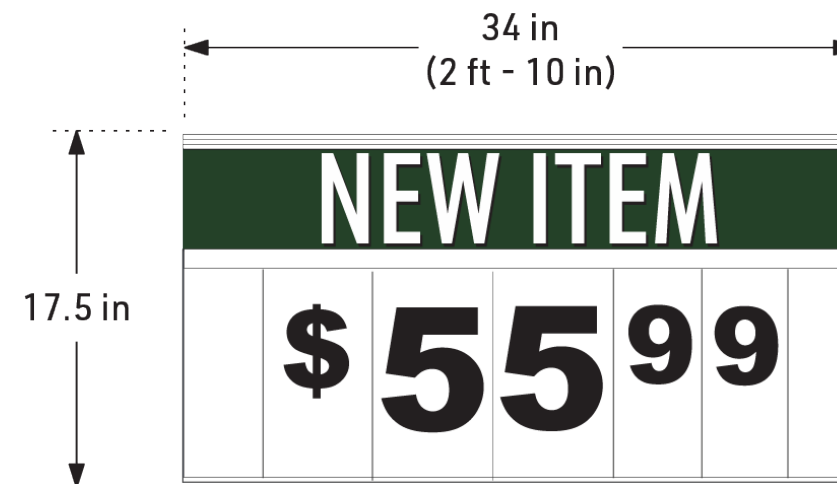

END CAP SIGNAGE

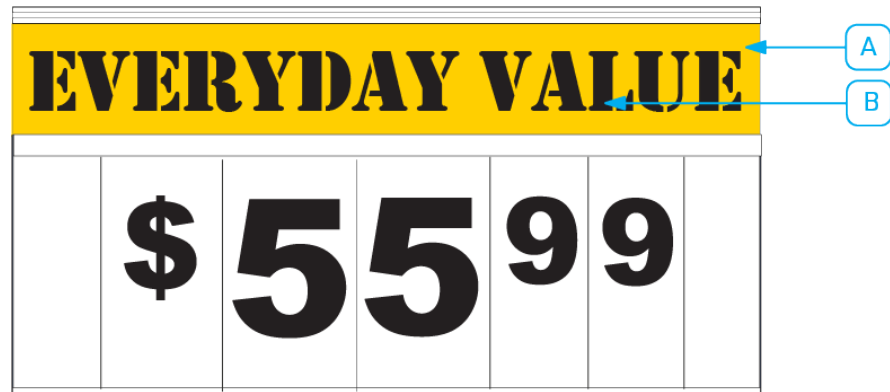

A	PMS MEDIUM YELLOW
B	FONT: STENCIL, BLACK



A	PMS 295C
B	FONT: UNIVERS, PMS 200C W/WHITE STROKE



A	PMS 5743C
B	FONT: AVENIR NEXT COND. BOLD, PMS 482C

RECTANGULAR AISLE DIRECTORY

Rectangular End Cap Signs are all-encompassing, providing both aisle and end cap signage in one. Their rectangular shape allows for the entire width of the directory to be used for logo branding and promoting impulse buying, while also creating dimension and further assistance in numbering the aisles.

Rectangle Directories Include:

- Logo/Graphic Panel
- Spiral Book Set (1)
- Message Inserts 36" (1) Set
- (2) Category Headers
- (6) Aisle Category Inserts
- (2) Toppers/Number Plaques

*Custom sizing available but will cause price to increase from standard costs

A	PANEL CAN BE A LOGO OR GRAPHIC.
B	NUMBER PANEL CAN BE A SOLID COLOR OR PRINTED GRAPHIC.
B	FONT CAN BE CUSTOMIZED AND/OR HAVE A SHADOW.
C	PANEL CAN BE A SOLID COLOR OR PRINTED GRAPHIC.
D	READING CAN BE CUSTOMIZED AND/OR HAVE A SHADOW.
F	PANEL CAN BE A SOLID COLOR OR PRINTED GRAPHIC.
G	READINGS CAN BE CUSTOMIZED.
H	PANEL CAN BE A SOLID COLOR OR PRINTED GRAPHIC.
I	READINGS CAN BE CUSTOMIZED AND/OR HAVE A SHADOW.

FRONT VIEW

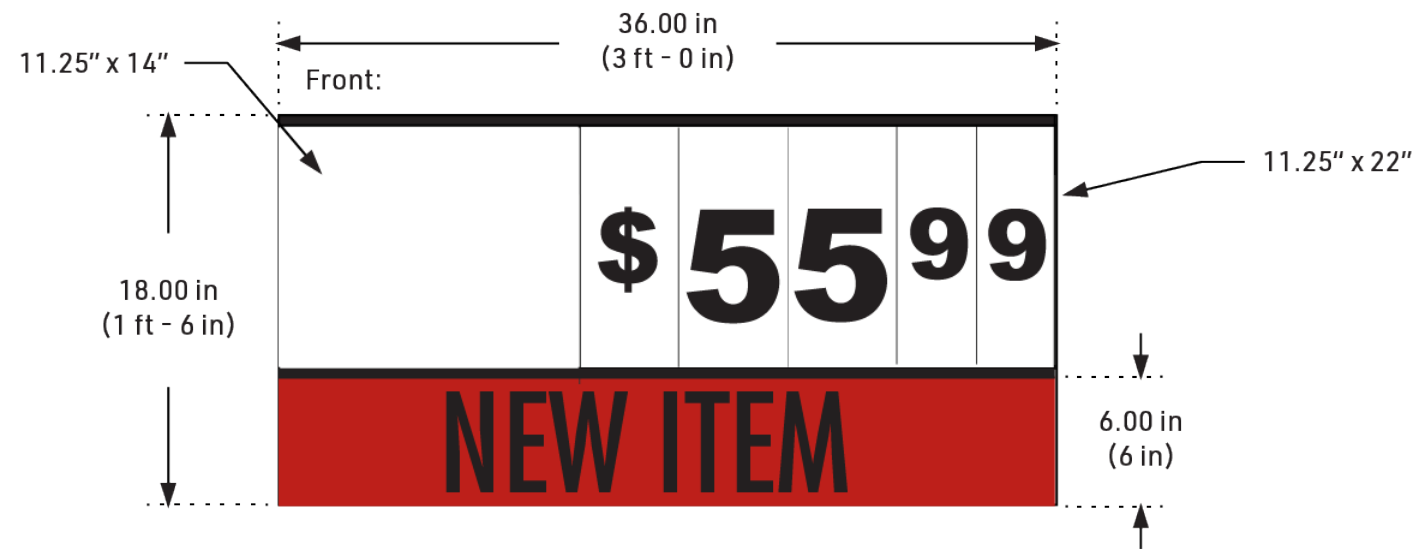

SIDE VIEW

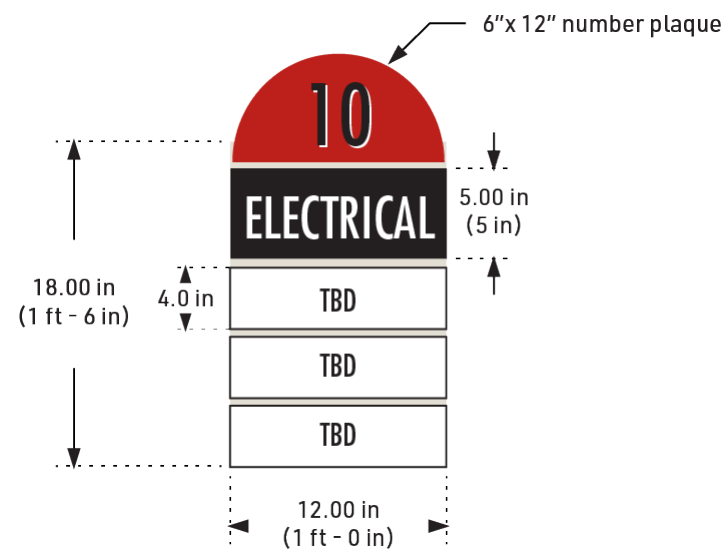

ANGLE VIEW

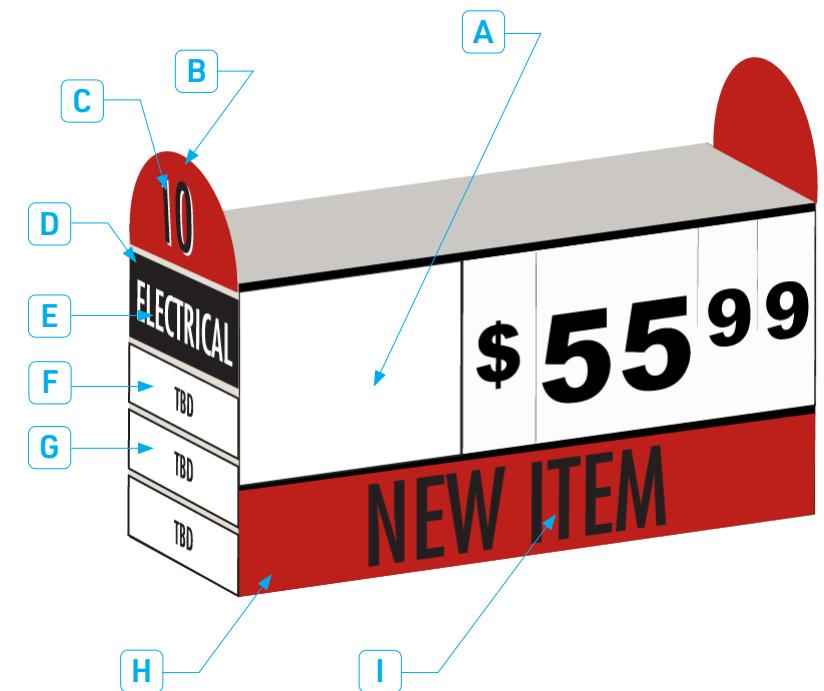

RECTANGULAR AISLE DIRECTORY



A	PANEL CAN BE A LOGO OR GRAPHIC.
B	NUMBER PANEL CAN BE A SOLID COLOR OR PRINTED GRAPHIC.
B	FONT CAN BE CUSTOMIZED AND/OR HAVE A SHADOW.
C	PANEL CAN BE A SOLID COLOR OR PRINTED GRAPHIC.
D	READING CAN BE CUSTOMIZED AND/OR HAVE A SHADOW.
F	PANEL CAN BE A SOLID COLOR OR PRINTED GRAPHIC.
G	READINGS CAN BE CUSTOMIZED.
H	PANEL CAN BE A SOLID COLOR OR PRINTED GRAPHIC.
I	READINGS CAN BE CUSTOMIZED AND/OR HAVE A SHADOW.



A	PANEL CAN BE A LOGO OR GRAPHIC.
B	NUMBER PANEL CAN BE A SOLID COLOR OR PRINTED GRAPHIC.
B	FONT CAN BE CUSTOMIZED AND/OR HAVE A SHADOW.
C	PANEL CAN BE A SOLID COLOR OR PRINTED GRAPHIC.
D	READING CAN BE CUSTOMIZED AND/OR HAVE A SHADOW.
F	PANEL CAN BE A SOLID COLOR OR PRINTED GRAPHIC.
G	READINGS CAN BE CUSTOMIZED.
H	PANEL CAN BE A SOLID COLOR OR PRINTED GRAPHIC.
I	READINGS CAN BE CUSTOMIZED AND/OR HAVE A SHADOW.

TRIANGLE AISLE DIRECTORIES

The Triangle Aisle Directories are designed to provide maximum visibility from any viewing angle. These are also designed to direct customers to products while working along with End Cap Price Signs, so you do not lose any promotional ability.

Number Plaque*: Made to accompany the Hanging and Triangle Aisle Directory signage. Each number plaque allows easy navigation between aisles. They are supplied in a set of (2) and are sized 9" x 9".

Aisle Inserts*: Sized 4" x 24", each kit includes (1) each of 350 readings.

*Number Plaques and Aisle Directory inserts sold separately.



A	PANEL CAN BE A SOLID COLOR OR A PRINTED GRAPHIC
B	PANEL CAN BE A SOLID COLOR OR A PRINTED GRAPHIC
C	FONT CAN BE CUSTOMIZED AND/OR HAVE A SHADOW

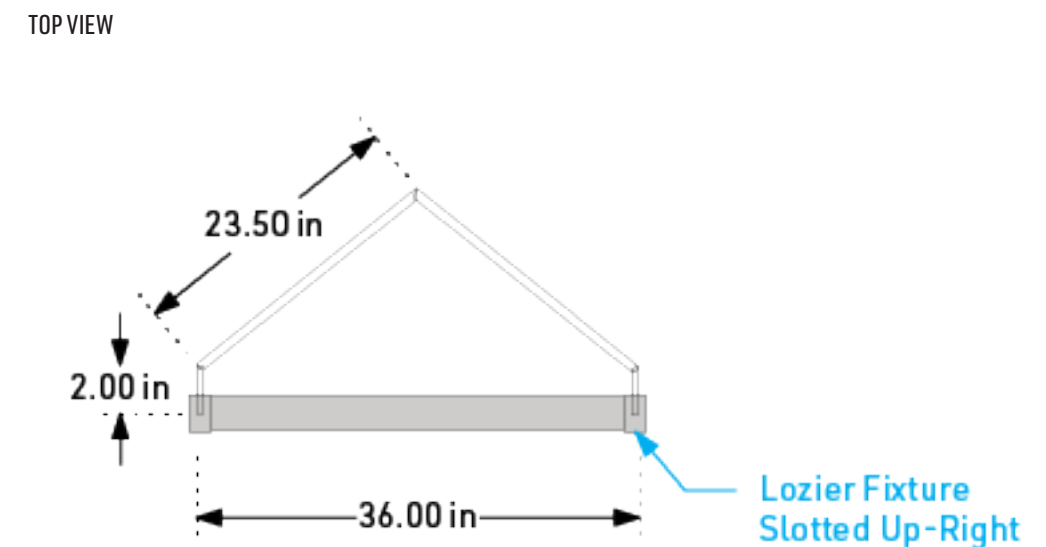

TRIANGLE AISLE DIRECTORIES



A	PMS 295C
B	PMS 877C
C	FONT: FUTURA (SIGN STANDARD), WHITE



A	PRINTED GRAPHIC
B	PMS 200C
C	FONT: LUBALIN GRAPH STD BOLD, BLACK W/ WHITE STROKE



A	PMS 350C
B	PRINTED GRAPHIC
C	FONT: TRAJAN PRO 3, WHITE W/ BLACK DROP SHADOW

TRAPEZOID AISLE DIRECTORIES

The Trapezoid Aisle Directories are similar to the triangles with the benefit of a flat front that allows for traffic fluidity in smaller spaces. Custom inserts, in your choice of colors, font and text are matched to other decor elements for a cohesive look, blending aesthetics and functionality. "Toppers" can be added to further promote your brand.

*Custom inserts and "Toppers" are sold separately.



A	PANEL CAN BE A SOLID COLOR
B	PANEL CAN BE A LOGO

TRAPEZOID AISLE DIRECTORY WITH TOPPER

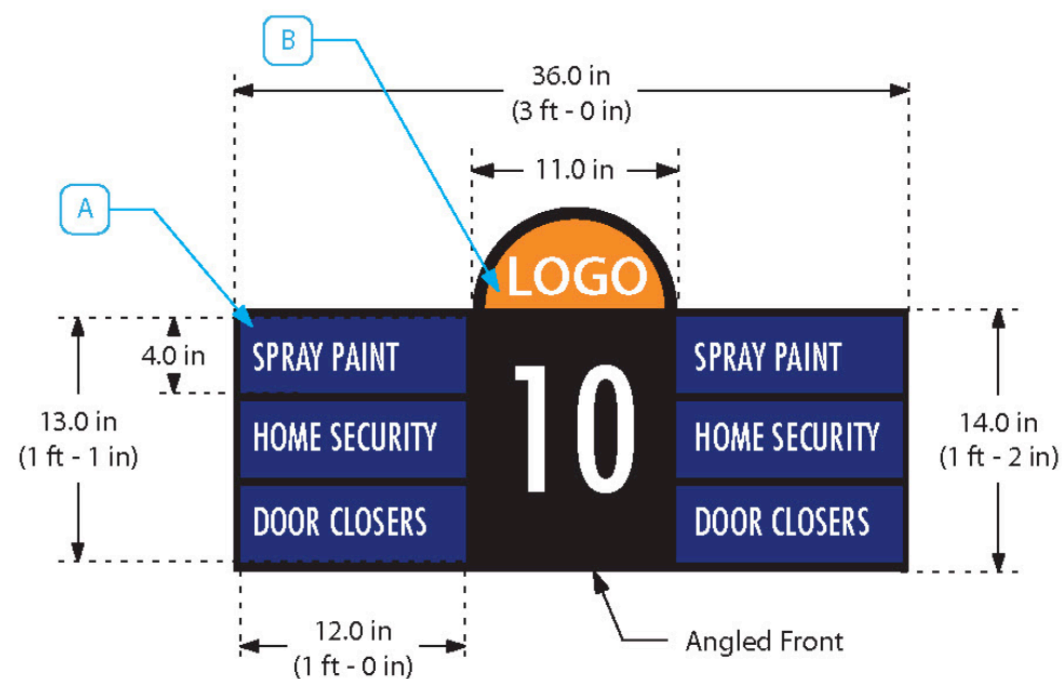

TRAPEZOID AISLE DIRECTORY

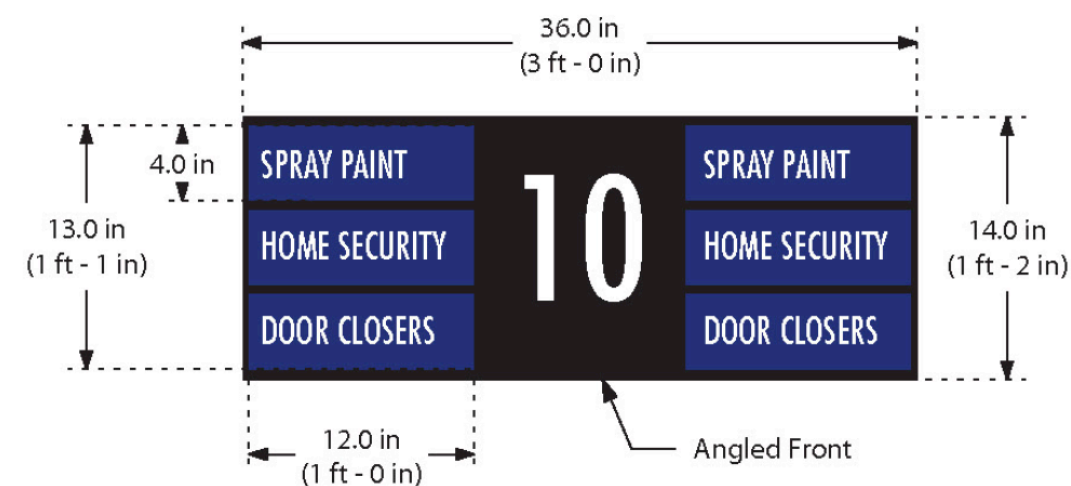

TRAPEZOID AISLE DIRECTORIES

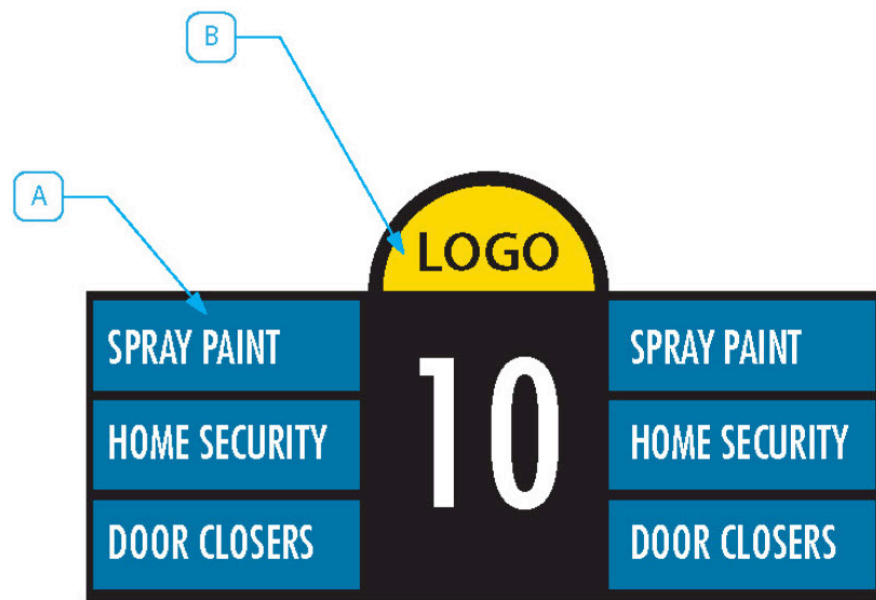

A	PMS 7690C AISLE INSERTS W/WHITE READING
B	MEDIUM YELLOWC W/BLACK READING



A	PMS 718C AISLE INSERTS W/WHITE READING
B	PRINTED LOGO PANEL



A	PMS COOL GRAY 7C AISLE INSERTS W/WHITE READING
B	PMS 200C W/ WHITE READING

HANGING AISLE SIGNAGE

Hanging Aisle Directories have versatility and can be placed in an aisle or over a fixture row. Aisle Identifiers direct the customer to specific product category offerings and selections. Changeable product category inserts allow for flexibility in department layout.

Number Plaque*: Made to accompany the Hanging and Triangle Aisle Directory signage. Each number plaque allows easy navigation between aisles. They are supplied in a set of (2) and are sized 9" x 9".

Aisle Inserts*: Sized 4" x 17", each kit includes (2) each of 125 readings.

Metal Mounting Frames are available for use with Hanging Aisle Directories. These frames are designed to be used with standard Lozier fixtures and some other manufacturers' fixture uprights.

A	PANEL CAN BE A SOLID COLOR OR A PRINTED GRAPHIC
B	PANEL CAN BE A SOLID COLOR OR A PRINTED GRAPHIC
C	FONT CAN BE CUSTOMIZED AND/OR HAVE A SHADOW

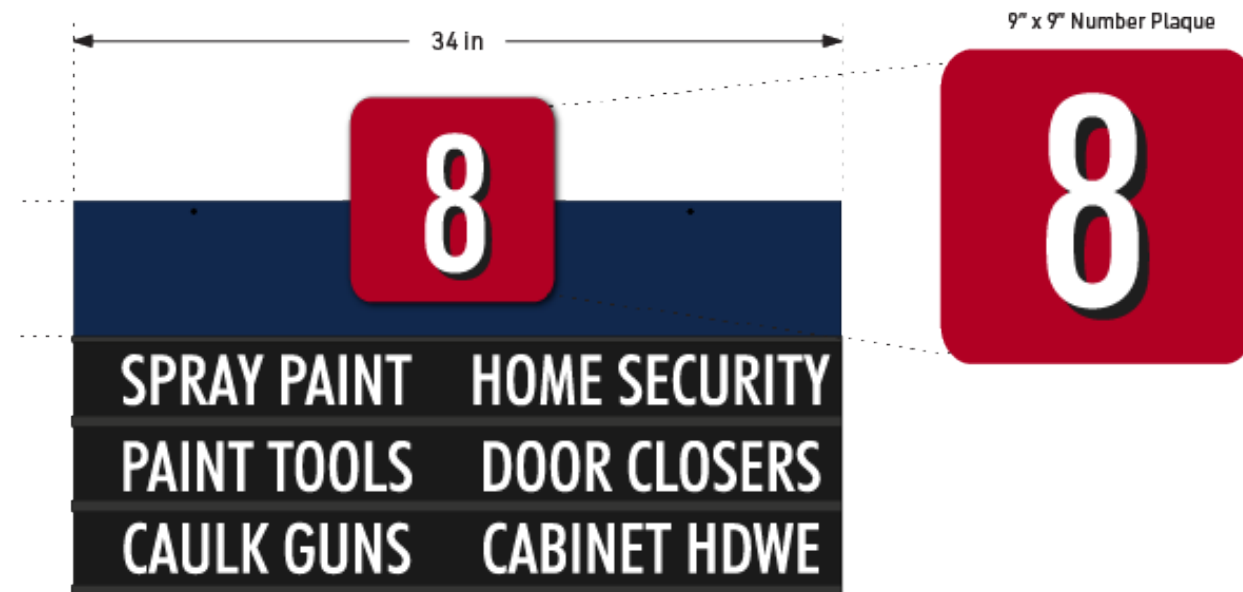
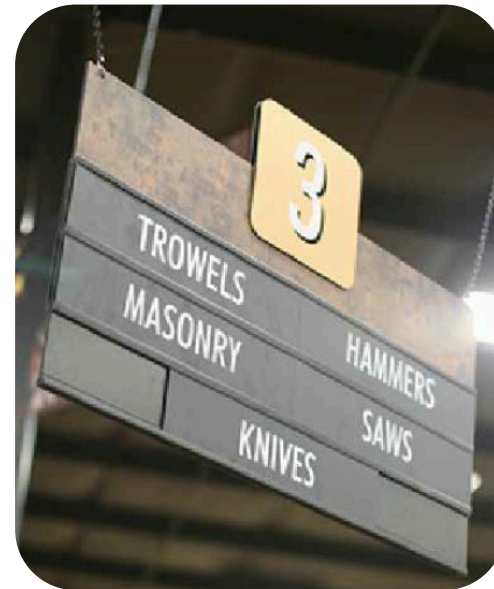

HANGING AISLE SIGNAGE

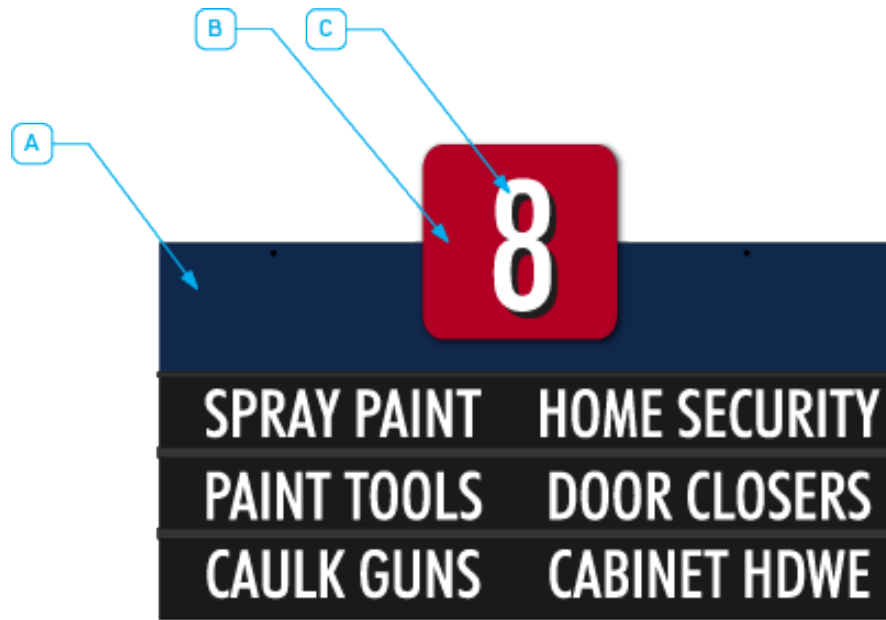

A	PMS 543C
B	PMS 200C
C	FONT: FUTURA (SIGN STANDARD), WHITE W/SHADOW

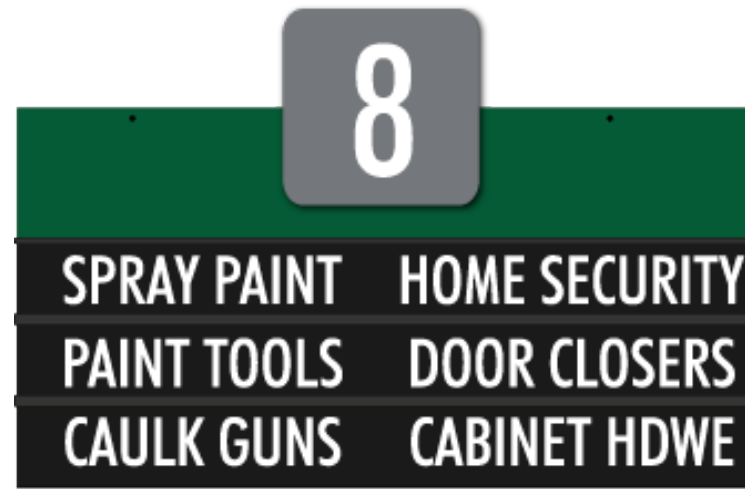

A	PMS 7727C
B	PMS COOL GRAY 8C
C	FONT: FUTURA (SIGN STANDARD), WHITE



A	PRINTED GRAPHIC
B	PMS 1375C
C	FONT: PALATINO BOLD, BLACK WITH WHITE DROP SHADOW

HANGING CIRCULAR SIGNAGE

Hanging Circular Signs creative visual impact through the use of shape, dimension, and color. They help with store branding and highlight key areas throughout the store while allowing signage to become part of the overall decor.

7.5 in Dimensional letter readings available.
Three 12 in high x .5 in foam boards with printed full color graphics also available.

A	PANEL CAN BE A SOLID COLOR OR A PRINTED GRAPHIC
B	PANEL CAN BE A SOLID COLOR OR A PRINTED GRAPHIC
C	PRINTED OR DIMENSIONAL LETTER OPTIONS AVAILABLE. LETTER FONT, COLOR, SIZE, ETC. CAN BE CUSTOMIZED
D	OPTIONAL PRINTED GRAPHICS OR LOGO

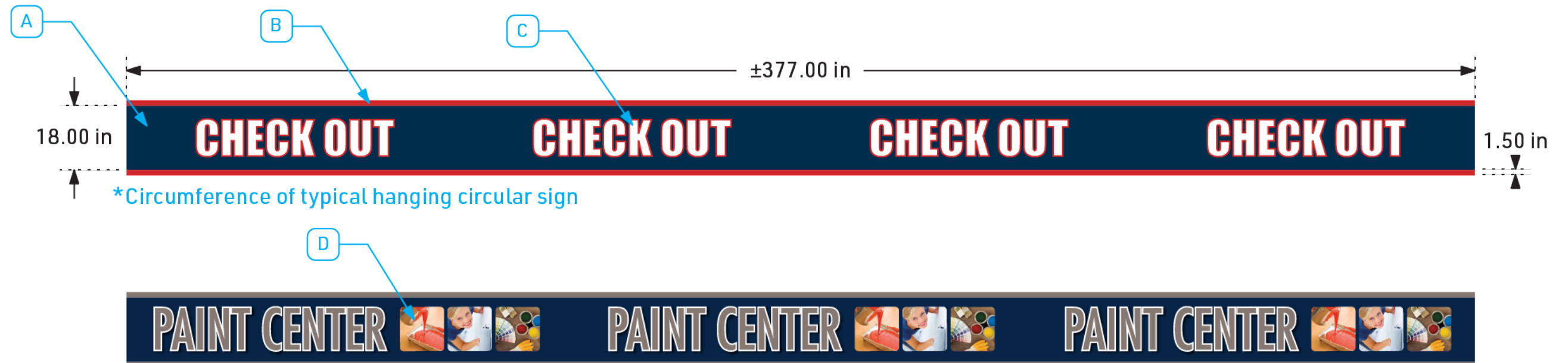

*Circumference of typical hanging circular sign

HANGING CIRCULAR SIGNAGE

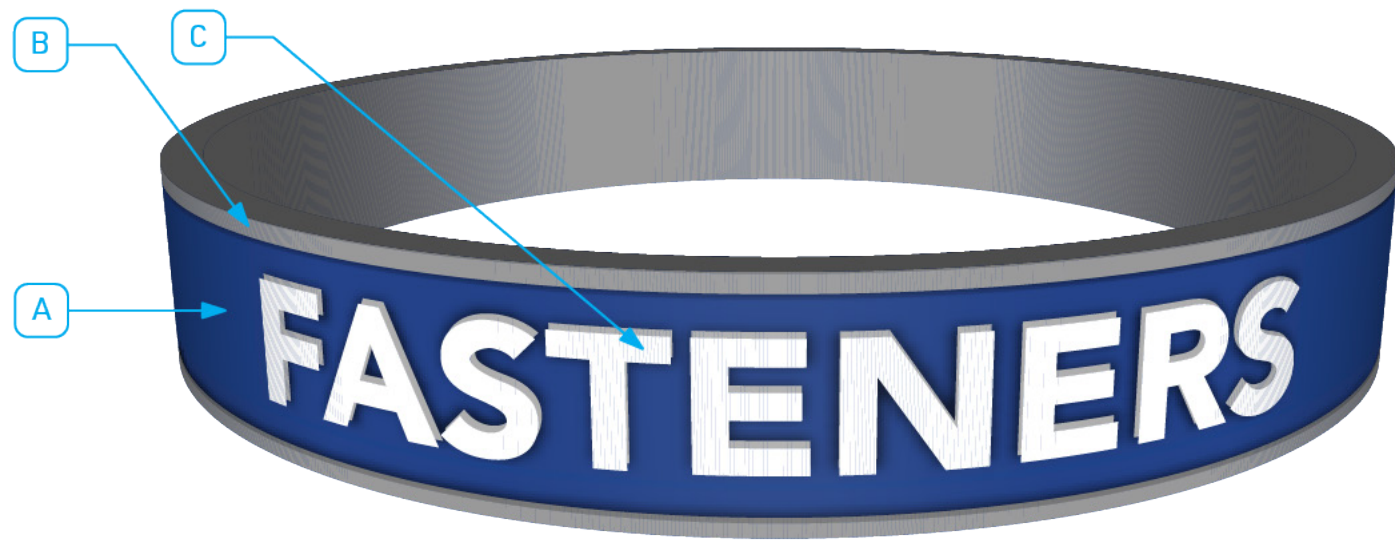

A	PMS 7687C
B	PMS COOL GRAY 7C
C	WHITE DIMENSIONAL LETTERS, FONT: AVENIR
D	N/A



A	PMS 181C
B	PMS 482C
C	PRINTED LETTERS, FONT: FACTORIA BLACK
D	PRINTED GRAPHICS

HANGING DEPARTMENT SIGNAGE

Bold, single or double sided, overhead department signs inform the customer as to the overall layout of the store, and guide them to core departments. Nearly unlimited in design, these full-color signs provide maximum impact and reinforce store branding.

Hanging department signs can be customized with any number of departments, each with their own accompanying graphic or lifestyling photograph. Logos can also be incorporated into the sign design, allowing for cohesive store identity.



HANGING DEPARTMENT SIGNAGE



CATEGORY MANAGEMENT SIGNAGE

Total Category Management (TCM) and Aisle Violator signage is a great tool to help navigate aisle content easily. System includes one double sided sign. Full-color, printed TCM signs available. TCM signs can also be customized with store branding.

Horizontal Hardware Kit: Kit includes hardware to mount (5) signs.

Vertical Hardware Kit: Kit includes hardware to mount (5) signs.

*Mounting hardware sold separately.

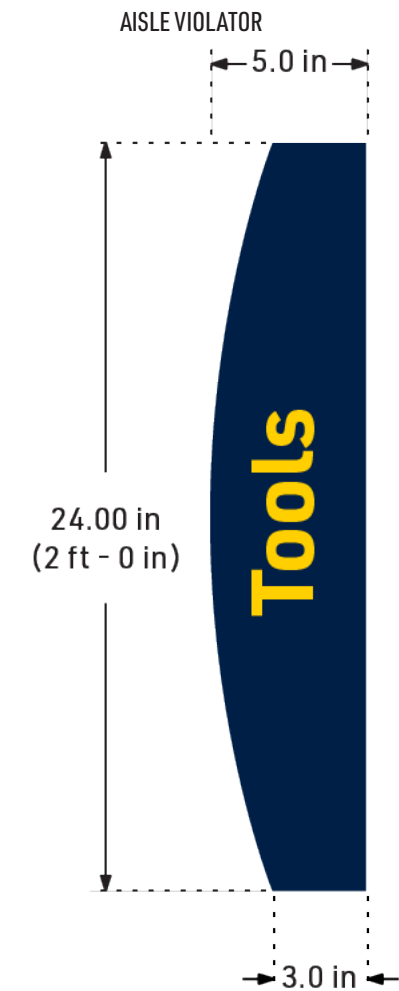
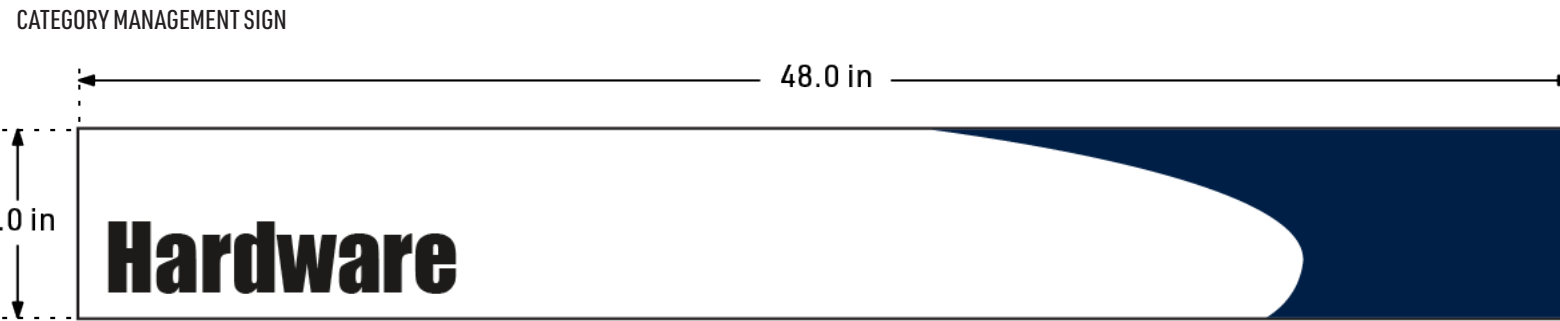

CATEGORY MANAGEMENT SIGNAGE

CATEGORY MANAGEMENT SIGN



AISLE VIOLATOR



SERVICE SIGNS

Service signs can quickly and efficiently let your customers know of all the special services you offer in your store. Single-Sided Sign includes pre-drilled holes for mounting to wall surface. Includes 16 item inserts. Double-Sided Sign also available.

Service Sign comes complete with interchangeable inserts:

- KEY CUTTING
- RE-KEYING LOCKS
- LOCK SERVICE
- SHARPENING SERVICE
- PIPE CUTTING
- PIPE THREADING
- POWER TOOL RE PAIR
- SMALL ENGINE REPAIR
- GLASS CUTTING
- PROPANE EXCHANGE
- TOOL SHARPENING
- LUMBER CUTTING
- ROPE & CHAIN CUTTING
- PRODUCT ASSEMBLY
- SPECIAL ORDERS
- DELIVERY

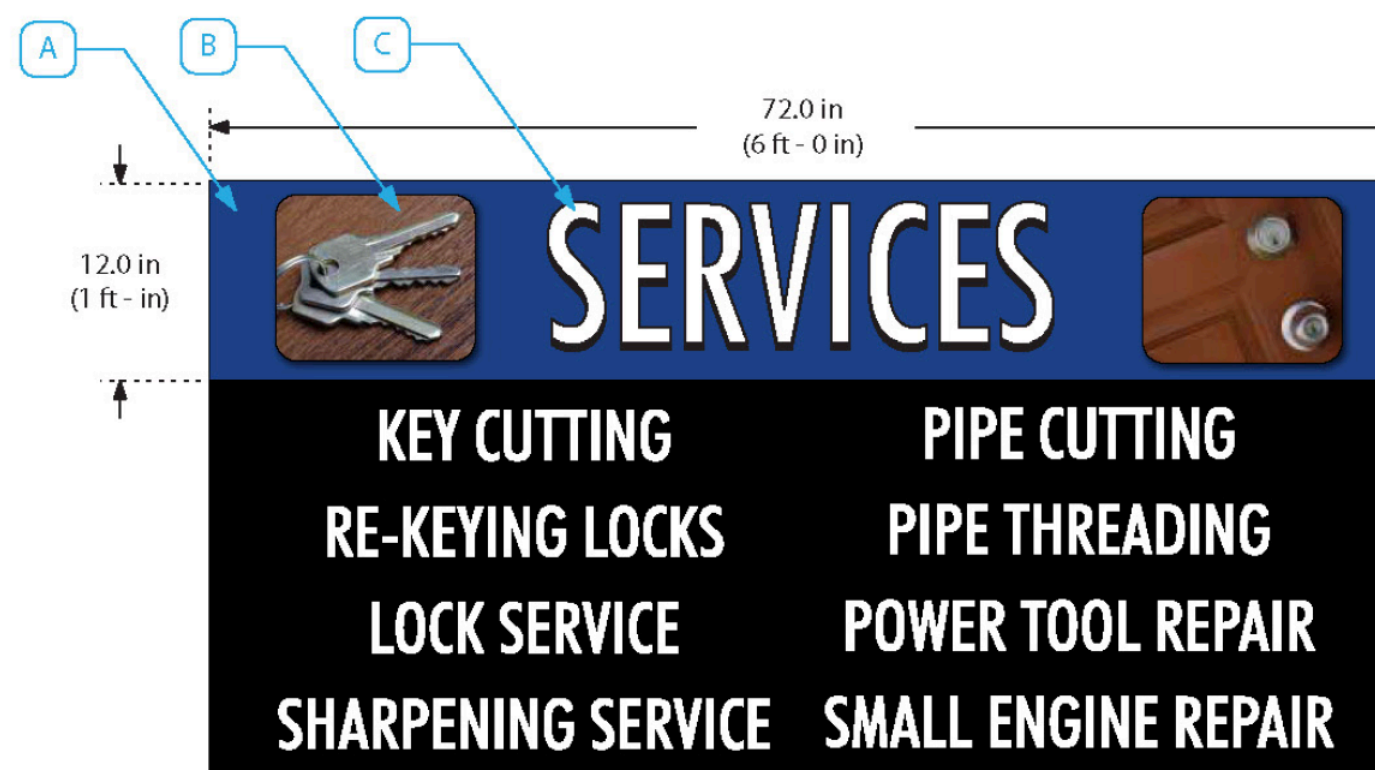
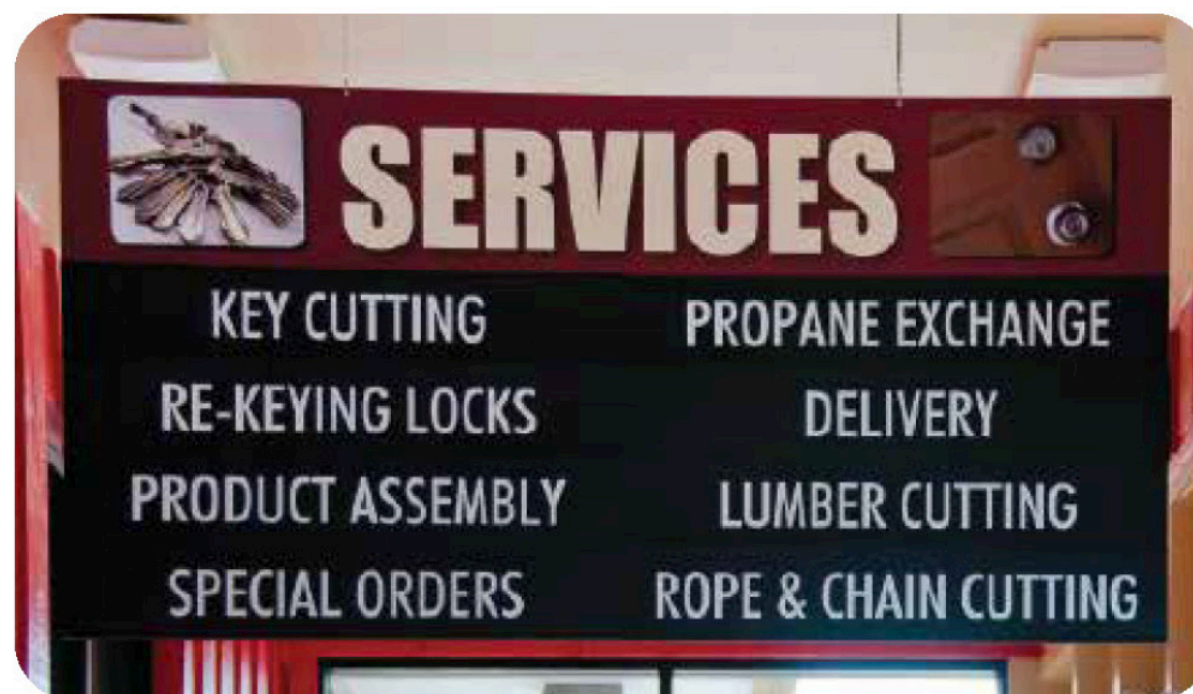

A	PANEL CAN BE A SOLID COLOR OR A PRINTED GRAPHIC
B	OPTIONAL PRINTED GRAPHICS OR LOGO
C	FONT CAN BE CUSTOMIZED AND/OR HAVE A SHADOW

SERVICE SIGNS

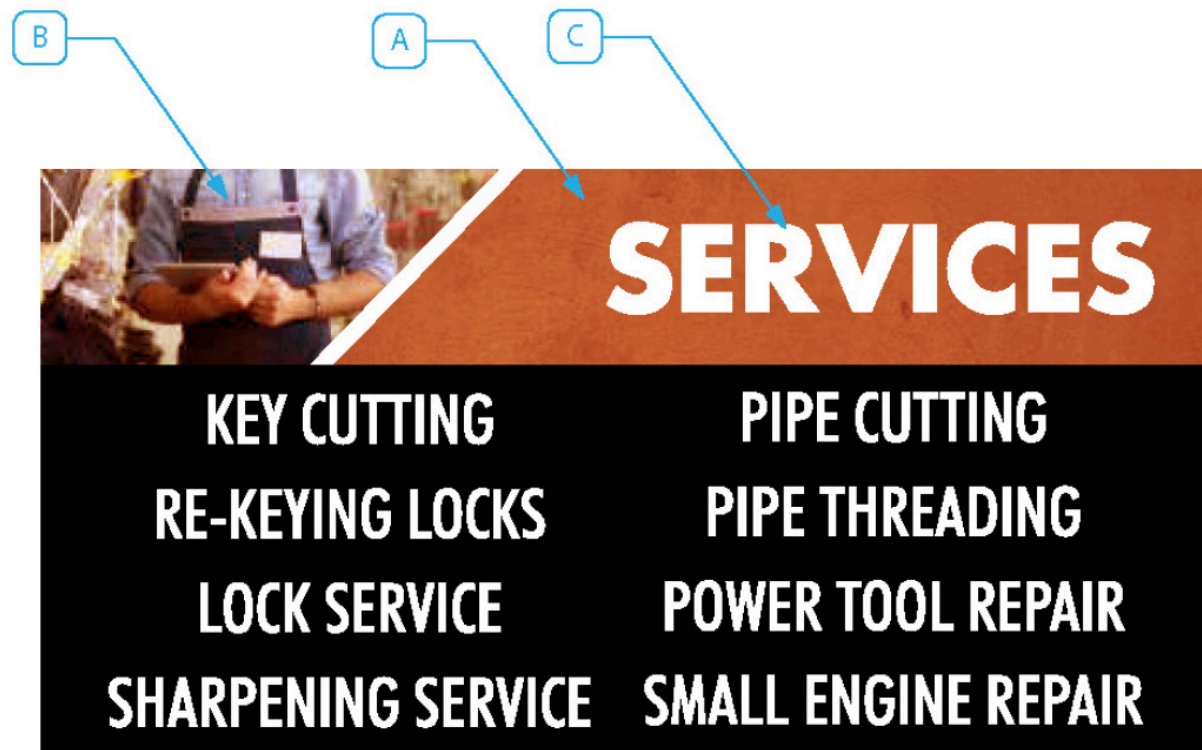

A	PRINTED PANEL
B	PRINTED GRAPHIC
C	WHITE FONT: FUTURA BOLD

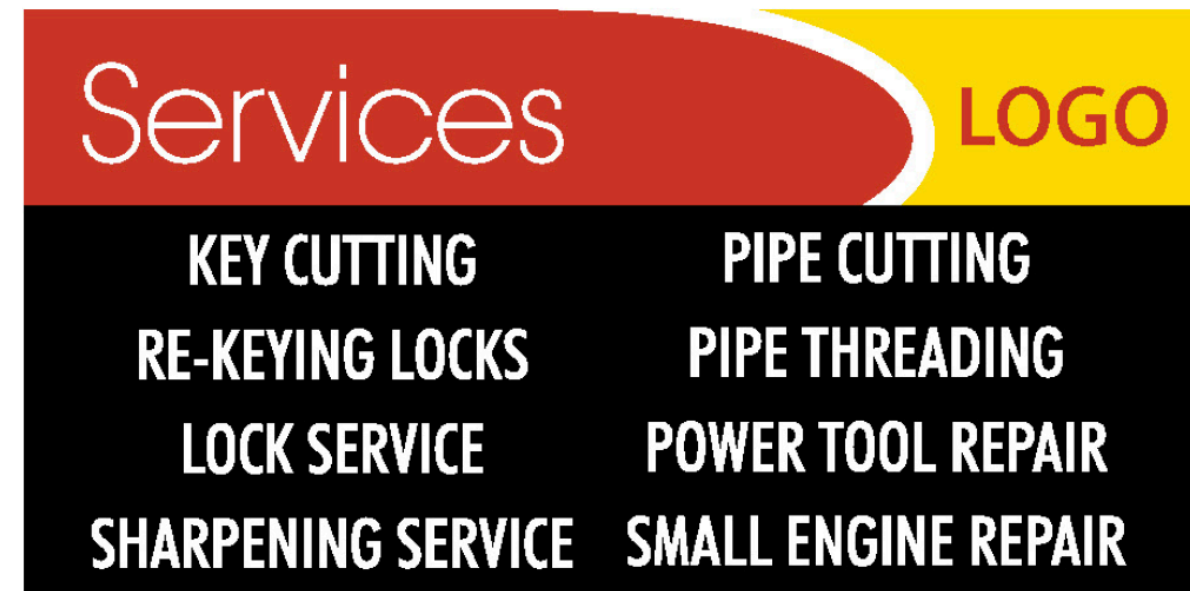

A	PRINTED PANEL
B	N/A
C	WHITE FONT: AVANT GARDE EXTRA LIGHT

COLORS

Below are examples of colors for use on signage, these are from the industry standard Pantone Matching System (PMS). There are many more colors available in the system, this is a small subset.

BRIGHT					MUTED					GRAYSCALE
										
MEDIUM YELLOW C	PMS 7408 C	PMS 1495 C	BRIGHT ORANGE C	BRIGHT RED C	7403 C	PMS 7556 C	7570 C	718 C	7608 C	WHITE C
										
PMS 295 C	MEDIUM PURPLE C	PMS 255 C	PMS 188 C	PMS 200 C	PMS 534 C	PMS 5275 C	PMS 5159 C	PMS 483 C	PMS 188 C	COOL GRAY 2 C
										
DARK BLUE C	MEDIUM BLUE C	PMS 0821 C	PMS 7467 C	PMS BRIGHT GREEN C	PMS 539 C	PMS 2995 C	PMS 7697 C	PMS 549 C	PMS 7467 C	COOL GRAY 7 C
										
PMS 389 C	PMS 360 C	PMS 356 C	PMS 350 C	PMS 356 C	PMS 7492 C	PMS 355 C	PMS 5763 C	PMS 626 C	PMS 5743 C	COOL GRAY 11 C
										
PMS 482 C	PMS 4645 C	PMS 470 C	PMS 462 C	PMS 476 C	WARM GRAY 1 C	PMS 7592 C	PMS 7531 C	PMS 7531 C	PMS 440 C	BLACK C

TEXTURES

Below are examples of textures for use on signage. Other textures are available, including customer supplied images. Note that due to the size of some signs, very high resolution images will need to be supplied for custom textures.



WOOD 01 - WEATHERED WHITEWASH

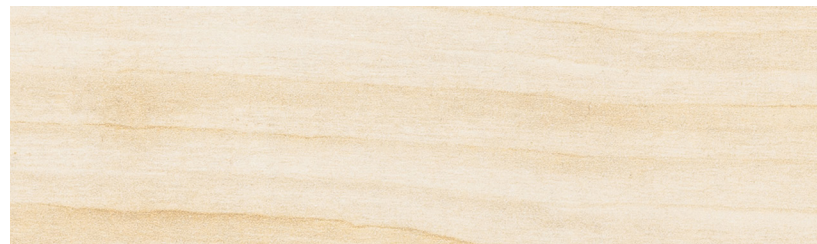

WOOD 05 - BIRCH



METAL 01 - BRUSHED STEEL



WOOD 02 - WEATHERED NATURAL



WOOD 06 - WEATHERED DARK BROWN



METAL 02 - GALVANIZED STEEL



WOOD 03 - HONEY TONED PLANKS



FABRIC 01 - LEATHER

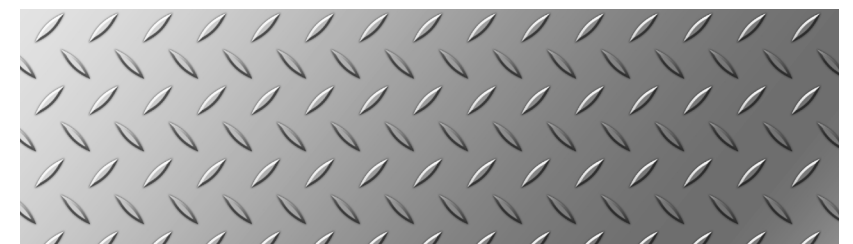

METAL 03 - SILVER DIAMONDPLATE

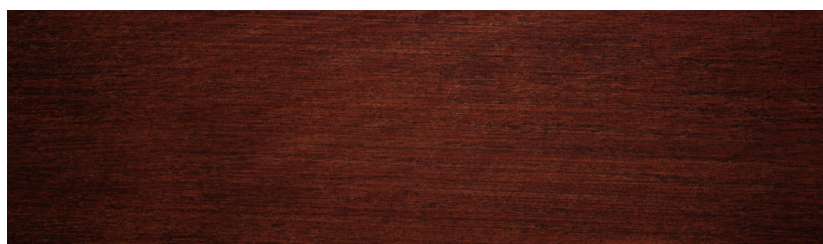

WOOD 04 - WALNUT

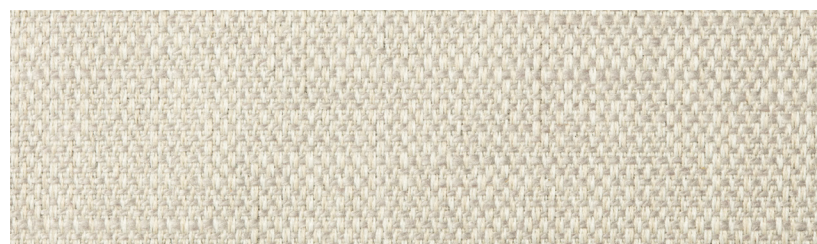

FABRIC 02 - BURLAP

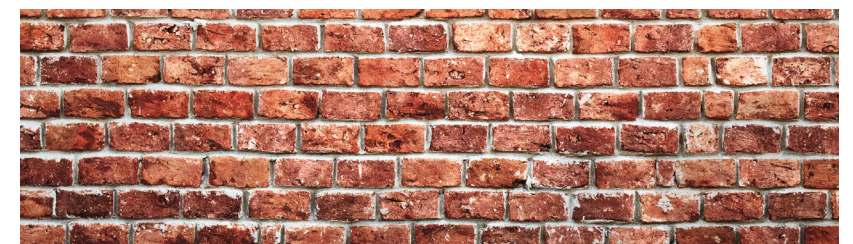

BRICK 01 - RED

CASE STUDY

CBS (Commonwealth Building Supplies), Bahamas

Commonwealth Building Supplies is a 80,000 SqFt store located in the Bahamas. It has multiple interior and exterior elements including custom designed murals and directional signage. The store is based on the custom decor package.



CASE STUDY

Buchheit Hardware, Illinois and Missouri

Buchheit Hardware is a 100,000 Sq. Ft. facility housing products from soft goods and home improvement, to sporting goods and farming supplies. Multiple elements including lifestyle graphics, directional signage, and aisle banners promote their brand as a community-oriented organization with pride in their rural roots.

